









User Manual





SL82

(Fold Inward) — — — — ▶

(Back Cover)

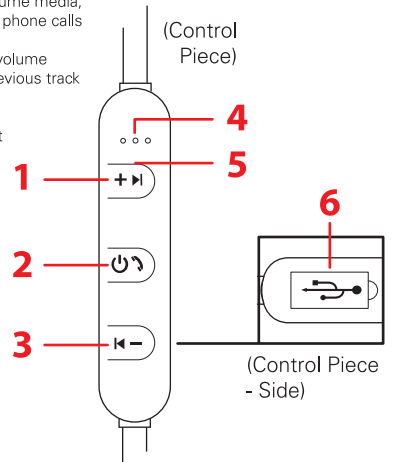
(Front Cover)

<h3>Compliance Information</h3> <p>FCC Information This device complies with Part 15 of the FCC Rules. Caution: Any changes or modifications not expressly approved could void the user's authority to operate the equipment. Note: This equipment has been tested and found to comply with the limits for a Class B digital device, pursuant to part 15 of the FCC Rules. These limits are designed to provide reasonable protection against harmful interference in a residential installation. This equipment generates, uses and can radiate radio frequency energy and, if not installed and used in accordance with the instructions, may cause harmful interference to radio communications. However, there is no guarantee that interference will not occur in a particular installation. If this equipment does cause harmful interference to radio or television reception, which can be determined by turning the equipment off and on, the user is encouraged to try to correct the interference by one or more of the following measures: – Reorient or relocate the receiving antenna. – Increase the separation between the equipment and receiver. – Connect the equipment into an outlet on a circuit different from that to which the receiver is connected. – Consult the dealer or an experienced radio/TV technician for help. This device complies with Part 15 of the FCC Rules. Operation is subject to the following two conditions: (1) This device may not cause harmful interference, and (2) this device must accept any interference received, including interference that may cause undesired operation. Radiation Exposure Information The device has been evaluated to meet general RF exposure requirement. The device can be used in portable exposure condition without restriction.</p> <p>WARNING Li-ion Battery Inside This product is fitted with a Li-ion battery. Do not damage, open, or dismantle the battery and do not use it in damp and/or corrosive conditions. Use only with compatible chargers. Never dispose of batteries in a fire, and never expose them to high temperatures. Do not expose the product to temperatures exceeding 60°C (140°F).</p> <p>Rating Label Definitions  Direct current symbol.  This symbol signifies the product must not be discarded as household waste, and should be delivered to an appropriate collection facility for recycling. Proper disposal and recycling helps protect natural resources, human health and the environment.  This symbol signifies and declares that this equipment has battery charging which complies with California CEC and energy efficiency.  This symbol signifies that this is a wireless device powered by Bluetooth® technology.</p>	<h3>Warranty Information</h3> <p><i>This product as supplied and distributed new by Southern Telecom, Inc. to the original consumer purchaser is warranted by Southern Telecom against defects in material and workmanship for a period of one year from your date of purchase ("Warranty"). In the unlikely event that this product is defective, or does not perform properly, you may within one year from your original date of purchase return it to the authorized service center for repair or exchange.</i></p> <p>Obtaining Warranty Service To obtain warranty service on your Polaroid product go to our website, SouthernTelecom.com, and click on Product Support. Select the Brand, then click on Service Request to get started.</p> <p>Your product will be repaired or replaced, at our option, for the same or similar model of equal value if examination by the service center determines this product is defective. Products received damaged as a result of shipping, will require you to file a claim with the carrier.</p> <p>IN NO EVENT WILL SOUTHERN TELECOM, ITS MANUFACTURERS, DISTRIBUTORS OR PLR IP HOLDINGS, LLC BE LIABLE FOR ANY INCIDENTAL, DIRECT, INDIRECT, SPECIAL, PUNITIVE OR CONSEQUENTIAL DAMAGES (SUCH AS, BUT NOT LIMITED TO, DAMAGES FOR LOSS OF PROFITS, BUSINESS, SAVINGS, DATA OR RECORDS) RELATED TO THIS PRODUCT, EXCEPT AS STATED HEREIN. NO OTHER WARRANTIES SHALL APPLY.</p> <p>Warranty Service Not Provided • This warranty does not cover damage resulting from accident, misuse, abuse, improper installation or operation, lack of reasonable care, or unauthorized modification. This warranty is voided in the event any unauthorized person opens, alters or repairs this product, all products being returned to the authorized service center for repair must be suitably packaged. • No warranties, whether express or implied, including, but not limited to, any implied warranties of merchantability or fitness for a particular purpose, other than those expressly described above shall apply. Distributor further disclaims all warranties after the express warranty period stated above. No other express warranty or guaranty given by any person, firm or entity with respect to the product shall be binding on distributor. Repair, replacement, or refund of the original purchase price – at distributor's sole discretion – are the exclusive remedies of the consumer. In no event will distributor or its manufacturers be liable for any incidental, direct, indirect, special, punitive or consequential damages (such as, but not limited to, damages for loss of products, business, savings, data or records) cause by the use, misuse or inability to use the product. Except as stated herein, no other warranties shall apply. Notwithstanding the foregoing, consumer's recovery against distributor shall not exceed the purchase price of the product sold by distributor. This warranty shall not extend to anyone other than the original consumer who purchased the product and is not transferable.</p> <p>Some countries, states or provinces do not allow the exclusion or limitation of incidental or consequential damages or allow limitations on warranties, so limitation or exclusions may not apply to you. This warranty gives you specific legal rights, and you may have other rights that vary from state to state or province to province. Contact your authorized retailer to determine if another warranty applies.</p> 	<p>All product names, trademarks, and registered trademarks are property of their respective owners. All company, product, and service names used in this document are for identification purposes only. Use of these names, trademarks, and brands does not imply endorsement.</p>  <p>Printed in China v1. 06-2019</p>	 <p>Instruction Manual Wireless Reflective Earbuds SL82</p> 
--	---	---	--

<h3>Before You Begin...</h3> <p>Customer Support For any questions or problems with your product, please visit our website at SouthernTelecom.com and click on Product Support.</p> <p>⚠ Caution To ensure safe and proper use, read all safety information before using the device. Only use with manufacturer-approved batteries, chargers, accessories, and supplies. • THIS DEVICE IS NOT A TOY. do NOT allow children or pets to use or play with this device. • Do not disassemble, modify, or repair the device. • Do not expose the device to extreme temperatures (heat or cold), open flames, humid, or wet conditions. • Do not submerge in water. • Low power may cause poor Bluetooth connection or sound distortion. • Do not overcharge battery. • If using with a USB adapter, make sure the adapter is not damaged. • Do not allow the USB port or the connectors of the supplied USB cable to be exposed to dust, or water, or come into contact with any conductive materials such as liquids, metallic powders, etc.</p> <p>In the Box</p> <ul style="list-style-type: none"> • SL82 - Wireless Earbuds (x1) • USB Charging Cable (x1) • S/M/L Eartips • User Manual (x1) 	<h3>Location of Controls</h3> <ol style="list-style-type: none"> 1. [+▶] Button: (Long Press) Increase volume (Quick Press) Skip to next track 2. [⏻] Button: (Long Press) Power ON/OFF (Quick Press) Pause/resume media, Answer/end phone calls 3. [◀-] Button: (Long Press) Decrease volume (Quick Press) Skip to previous track 4. Microphone 5. LED Indicator 6. Micro-USB Charging Port 	<h3>Getting Started</h3> <p>Charging the Earbuds Attach the small connector of the supplied micro-USB cable to the USB charging port on the side of the earbuds. Attach the large connector to the USB port on a computer, a USB charging device, or a 5V USB adapter (not included) and plug into a wall socket.</p> <p>The LED indicator will turn RED while charging and turn BLUE when fully charged. When low on power, a tone will be heard, indicating that the earbuds should be charged.</p> <p>Power ON/OFF • Long press the [⏻] button to power the earbuds ON/OFF.</p> <p>Bluetooth Pairing 1. Power the earbuds ON. A tone will be heard and the LED indicator will flash RED and BLUE. 2. Set your mobile device to search for Bluetooth devices. When it appears, select SL82 from the list of found devices. 3. Once successfully paired, a tone will be heard and the LED indicator will turn BLUE.</p> <p>When powered ON, the earbuds will automatically reconnect to the device it was most recently paired to, so long as that device is within connection range (30 ft.) and Bluetooth is enabled.</p>	<div data-bbox="2113 1408 2370 1648" style="border: 1px solid black; padding: 5px;"> <p>LED Indicator</p> <ul style="list-style-type: none">  Flashing RED and BLUE Earbuds are ready to pair  Solid BLUE Earbuds are paired Earbuds are fully charged  Solid RED Earbuds are charging </div> <p>Playing Music To listen to music on your earbuds, make sure they are paired to a Bluetooth-enabled device. For more on pairing the earbuds to your device, please consult the Bluetooth Pairing section of this user manual.</p> <p>Once paired, you can control media playback and volume adjustment with the earbud's controls or on your paired device.</p> <p>Controlling Playback</p> <ul style="list-style-type: none"> • Quick press the [⏻] button to play/pause media playback. • Quick press the [◀-] and [+▶] buttons to skip tracks. • Long press the [◀-] and [+▶] buttons to adjust volume. A tone will be heard if trying to increase the volume past the maximum level. <p>Phone Calls</p> <ul style="list-style-type: none"> • Quick press the [⏻] button to answer an incoming phone call or end an existing one. • Long press the [⏻] button to send an incoming phone call to your voicemail. • Double quick press the [⏻] button to redial the last number called on your phone.
--	---	--	--