









User Manual

PBGA15

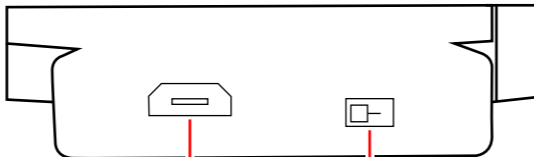
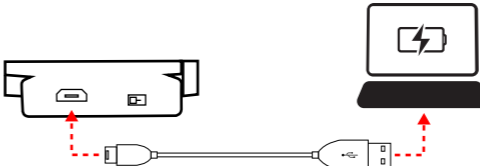
<p style="text-align: center;">Warranty Information</p> <p>90-day Limited Warranty Territory: United States/Canada</p> <p>LIMITED WARRANTY TO ORIGINAL CONSUMER This product (including any accessories included in the original packaging) as supplied and distributed new by an authorized retailer is warranted by Southern Telecom, Inc. to the original consumer purchaser against defects in materials and workmanship ("Warranty") as follows:</p> <p>To obtain warranty service:</p> <ul style="list-style-type: none"> • Visit our website at www.southern telecom.com • Click on Product Support • Select the Brand of your device • Select Service Request and fill out the form to begin your inquiry <p>Your product will be repaired or replaced, at our option, for the same or similar model of equal value if examination by the service center determines this product is defective. Products received damaged as a result of shipping will require you to file a claim with the carrier.</p> <p>Warranty service not provided This warranty does not cover damage resulting from accident, misuse, abuse, improper installation or operation, lack of reasonable care, unauthorized modification including software modifications such as the installation of custom firmware. This warranty is voided in the event any unauthorized person opens, alters or repairs this product. All products being returned to the authorized service center for repair must be suitably packaged.</p>	<p style="text-align: center;">Warranty Information (cont'd)</p> <p>NO WARRANTIES, WHETHER EXPRESS OR IMPLIED, INCLUDING, BUT NOT LIMITED TO, ANY IMPLIED WARRANTIES OF MERCHANTABILITY OR FITNESS FOR A PARTICULAR PURPOSE, OTHER THAN THOSE EXPRESSLY DESCRIBED ABOVE SHALL APPLY. DISTRIBUTOR FURTHER DISCLAIMS ALL WARRANTIES AFTER THE EXPRESS WARRANTY PERIOD STATED ABOVE. NO OTHER EXPRESS WARRANTY OR GUARANTY GIVEN BY ANY PERSON, FIRM OR ENTITY WITH RESPECT TO THE PRODUCT SHALL BE BINDING ON DISTRIBUTOR, REPAIR, REPLACEMENT, OR REFUND OF THE ORIGINAL PURCHASE PRICE - AT DISTRIBUTOR'S SOLE DISCRETION - ARE THE EXCLUSIVE REMEDIES OF THE CONSUMER. IN NO EVENT WILL DISTRIBUTOR OR ITS MANUFACTURERS BE LIABLE FOR ANY INCIDENTAL, DIRECT, INDIRECT, SPECIAL, PUNITIVE OR CONSEQUENTIAL DAMAGES (SUCH AS, BUT NOT LIMITED TO, DAMAGES FOR LOSS OF PROFITS, BUSINESS, SAVINGS, DATA OR RECORDS) CAUSED BY THE USE, MISUSE OR INABILITY TO USE THE PRODUCT, EXCEPT AS STATED HEREIN. NO OTHER WARRANTIES SHALL APPLY. NOTWITHSTANDING THE FOREGOING, CONSUMER'S RECOVERY AGAINST DISTRIBUTOR SHALL NOT EXCEED THE PURCHASE PRICE OF THE PRODUCT SOLD BY DISTRIBUTOR. THIS WARRANTY SHALL NOT EXTEND TO ANYONE OTHER THAN THE ORIGINAL CONSUMER WHO PURCHASED THE PRODUCT AND IS NOT TRANSFERABLE.</p> <p>Some countries, states or provinces do not allow the exclusion or limitation of incidental or consequential damages or allow limitations on warranties, so limitation or exclusions may not apply to you. This warranty gives you specific legal rights, and you may have other rights that vary from state to state or province to province. Contact your authorized retailer to determine if another warranty applies.</p>	<div style="text-align: center;">   </div> <p>PBX® is a registered trademark of PBX® Holdings, LLC. All other trademarks and trade names are those of their respective owners.</p> <p>Designed in US Printed in China v1, 01-2020</p>	<div style="text-align: center;">  <p>PBGA15 ARCTIC Mobile Cooling Controller Instruction Manual</p>  </div>
--	---	---	--

<p style="text-align: center;">Before You Begin</p> <p>In the Box</p> <ul style="list-style-type: none"> • PBGA15 - Mobile Cooling Controller (x1) • USB Charging Cable (x1) • User Manual (x1) <p>Caution To ensure safe and proper use, read all safety information before using the devices. Only use with manufacturer-approved batteries, chargers, accessories, and supplies.</p> <ul style="list-style-type: none"> • THIS DEVICE IS NOT A TOY. do NOT allow children or pets to use or play with these devices. • Do not disassemble, modify, or repair the devices. • Do not submerge in water. • Do not expose the units to extreme temperatures (heat or cold), open flames, humid, or wet conditions. • Do not allow the USB ports, power jack or other inputs of the devices to be exposed to dust, or water, or come into contact with any conductive materials such as liquids, metallic powders, etc. • Do not overcharge the battery • Do not open this product or attempt to repair the unit yourself should it not be working. • The headphones should not be disposed of with regular household waste. Please consult the local authorities on the correct way to dispose of this device. <p>Customer Support For any questions or problems with your product, please visit our website at SouthernTelecom.com and click on Product Support.</p>	<p style="text-align: center;">Location of Controls</p> <p style="text-align: center;">(Bottom of Controller)</p>  <p style="text-align: center;">Charging Port [Power] Switch</p>	<p style="text-align: center;">Getting Started</p> <p>Charging the Controller Insert the small connector of the supplied USB charging cable into the charging port on the bottom of the controller. Insert the large connector into the USB port on a computer, a USB charging device, or a 5V/1A USB adapter (not included) and plug into an electrical outlet.</p>  <p>Installing your Device For the best fit, remove any case or covering from your device.</p> <p>Pull the handles apart to extend the controller so that it will fit your device. Slide your device into the controller from the top, face up. Gently release the handles to tighten around your device.</p> <p>Using the Fan Move the [Power] switch to power the fan ON and OFF.</p>	<p style="text-align: center;">Compliance Information</p> <p>FCC Information This device complies with Part 15 of the FCC Rules.</p> <p>Caution: Any changes or modifications not expressly approved could void the user's authority to operate the equipment.</p> <p>Note: This equipment has been tested and found to comply with the limits for a Class B digital device, pursuant to part 15 of the FCC Rules. These limits are designed to provide reasonable protection against harmful interference in a residential installation. This equipment generates, uses and can radiate radio frequency energy and, if not installed and used in accordance with the instructions, may cause harmful interference to radio communications. However, there is no guarantee that interference will not occur in a particular installation. If this equipment does cause harmful interference to radio or television reception, which can be determined by turning the equipment off and on, the user is encouraged to try to correct the interference by one or more of the following measures:</p> <ul style="list-style-type: none"> -- Reorient or relocate the receiving antenna. -- Increase the separation between the equipment and receiver. -- Connect the equipment into an outlet on a circuit different from that to which the receiver is connected. -- Consult the dealer or an experienced radio/TV technician for help. <p>This device complies with Part 15 of the FCC Rules. Operation is subject to the following two conditions: (1) This device may not cause harmful interference, and (2) this device must accept any interference received, including interference that may cause undesired operation.</p> <p>Radiation Exposure Information This device has been evaluated to meet general RF exposure requirements. The device can be used in portable exposure conditions without restriction.</p> <p>Lithium Polymer Battery Warnings This device contains a non-removable Lithium-Polymer battery. The battery must be recycled or disposed of properly. Contact your local waste management office for information on battery recycling or disposal.</p> <p>Rating Label Definitions</p> <ul style="list-style-type: none">  Direct current symbol.  This symbol signifies the product must not be discarded as household waste, and should be delivered to an appropriate collection facility for recycling. Proper disposal and recycling helps protect natural resources, human health and the environment.  This symbol signifies and declares that this equipment has battery charging which complies with California CEC and energy efficiency.  This symbol represents FCC Declaration of Conformity and compliance.
--	--	---	---