

Brookstone®

ISOLATENX

Active Noise-Cancelling
Headphones



TABLE OF CONTENTS

Compliance Information.....	1
Before You Begin...	
Additional Warnings.....	3
In the Box.....	3
Location of Controls.....	4
Getting Started	
Charging the Headphones.....	5
Powering ON/OFF.....	5
ANC.....	5
Bluetooth Pairing.....	6
Volume and Playback.....	6
Answering Phone Calls.....	6
Connecting with 3.5mm AUX cable.....	7
Warranty Information.....	9

FCC Information

This device complies with Part 15 of the FCC Rules.

Caution: Any changes or modifications not expressly approved could void the user's authority to operate the equipment.

Note: This equipment has been tested and found to comply with the limits for a Class B digital device, pursuant to part 15 of the FCC Rules. These limits are designed to provide reasonable protection against harmful interference in a residential installation. This equipment generates, uses and can radiate radio frequency energy and, if not installed and used in accordance with the instructions, may cause harmful interference to radio communications. However, there is no guarantee that interference will not occur in a particular installation. If this equipment does cause harmful interference to radio or television reception, which can be determined by turning the equipment off and on, the user is encouraged to try to correct the interference by one or more of the following measures:

- Reorient or relocate the receiving antenna.
- Increase the separation between the equipment and receiver.
- Connect the equipment into an outlet on a circuit different from that to which the receiver is connected.
- Consult the dealer or an experienced radio/TV technician for help.

This device complies with Part 15 of the FCC Rules. Operation is subject to the following two conditions: (1) This device may not cause harmful interference, and (2) this device must accept any interference received, including interference that may cause undesired operation.

Radiation Exposure Information

This device has been evaluated to meet general RF exposure requirements. The device can be used in portable exposure conditions without restriction.

LITHIUM POLYMER BATTERY WARNINGS

This device contains a non-removable Lithium-Polymer battery. The battery must be recycled or disposed of properly. Contact your local waste management office for information on battery recycling or disposal.



Rating Label Definitions

 Direct current symbol.



This symbol signifies the product must not be discarded as household waste, and should be delivered to an appropriate collection facility for recycling. Proper disposal and recycling helps protect natural resources, human health and the environment.



This symbol signifies and declares that this equipment has battery charging which complies with California CEC and energy efficiency.



This symbol signifies that this is a wireless device powered by Bluetooth® technology. The Bluetooth® word mark and logos are registered trademarks owned by Bluetooth SIG, Inc., used under license.



Before You Begin...

READ THIS MANUAL CAREFULLY AND SAVE FOR FUTURE REFERENCE

To ensure safe and proper use, read all safety information before using the device. Only use with manufacturer-approved batteries, chargers, accessories, and supplies.

- **THIS DEVICE IS NOT A TOY**, do NOT allow children or pets to use or play with this device.
- **Do not disassemble, modify, or repair the device.**
- Do not expose the device to extreme temperatures (heat or cold), open flames, humid, or wet conditions.
- ***Do not submerge in water.***
- Low power may cause poor Bluetooth connection or sound distortion.
- Use of the ANC (active noise cancellation) function may reduce battery life more quickly.
- Do not overcharge battery.
- If using with a USB adapter, make sure the adapter is not damaged.
- Do not allow the USB port or the connectors of the supplied USB cable to be exposed to dust, or water, or come into contact with any conductive materials such as liquids, metallic powders, etc.
- ***Always be aware of your surroundings when using the headphones.***
- ***Never use headphones while driving a vehicle, riding a bicycle, or operating anything that requires your undivided attention***

In the Box

- BSNCH102 - Wireless Headphones (x1)
- USB Charging Cable (x1)
- 3.5 mm AUX Cable (x1)
- Instruction Manual (x1)

Location of Controls

1. LED Indicator
2. Microphone
3. 3.5 mm AUX Port
4. Micro-USB Charging Port
5. **[ANC Power] Button**:
Press: Turn Active Noise Cancelling ON/OFF
6. **[-<<] Button**:
Press: Decrease volume
Press + hold: Skip to previous track
7. **[▶||] Button**:
Press: Pause and resume playback,
Answer and end phone call
Press + hold (3s): Power ON/OFF
8. **[▶▶+] Button**:
Press: Increase volume
Press + hold: Skip to next track

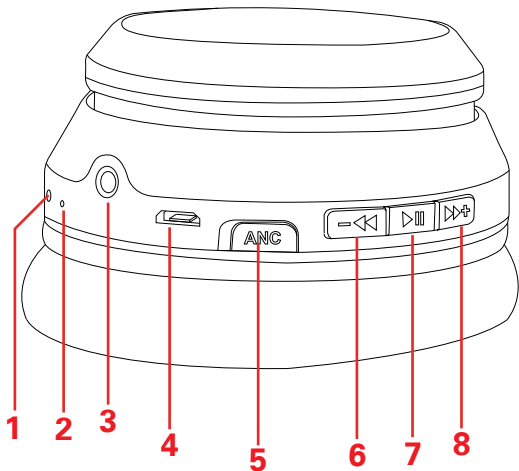

Charging the Headphones

Plug the small connector of the included charging cable into the charging port on the bottom of the headphones' earcup. Plug the large connector into a USB power source, such as the USB port on a computer, or a 5V USB wall adapter (*not included*).

The LED indicator on the headphones will turn RED while charging and turn BLUE when finished charging.

Powering ON/OFF

- Press and hold the [►||] button for 3 seconds to power the headphones ON and OFF.
- When powered on, the headphones may automatically reconnect to a nearby previously-paired device with Bluetooth enabled. To disconnect and enter Bluetooth pairing mode, press + hold the [►||] button for 5 seconds.

Using the Active Noise Control

Warning: Read all Safety Warnings in this manual before using the Active Noise Cancelling feature.

The headphones' Active Noise Control (noise cancelling) feature reduces unwanted noise from the outside environment. You can use ANC while listening to audio, or use ANC by itself.

- Press the [ANC Power] button to turn on Active Noise Control (noise cancellation). A voice will be heard, and the LED indicator will light up GREEN.
- Press the [ANC Power] button again to turn ANC OFF. A voice will be heard, and the LED indicator will turn OFF.

Playing Music

To listen to music on the headphones, you must be paired to a Bluetooth-enabled device or connected via the 3.5 mm AUX port. Consult the **Bluetooth Pairing** or **Connecting with a 3.5 mm AUX Cable** sections of this manual for further instruction.

Bluetooth Pairing

1. Power the headphones ON. A voice will be heard, and the LED indicator will **flash BLUE and RED**.
2. Set your mobile device to search for Bluetooth devices. Select **BSNCH102** from the list of found devices.
3. After a successful pairing, a voice will be heard and the LED indicator will **slowly flash BLUE**, and will flash BLUE while playing music.

In Bluetooth mode, playback and volume can be adjusted with the on-ear controls, or with your paired device.

- Press the [▶||] button to pause and resume playback.
- Press the [◀◀] and [▶▶] buttons to adjust volume.
- *Press and hold* the [◀◀] and [▶▶] buttons to skip tracks.

Phone Calls

To use the phone functions on the headphones, you must be connected to a Bluetooth-enabled device.

- Press the [▶||] button to answer and end phone calls. Playback will automatically pause and resume.
- 2x press the [▶||] button to dial the last outgoing phone number.
- *Press and hold* the [▶||] button for 2 seconds to reject an incoming call.

Connecting with the 3.5 mm AUX Cable

Plug one connector of the included 3.5 mm auxiliary cable into the 3.5 mm aux input port on the bottom of the right earcup. Plug the other connector into the audio output port on your media-playing device.

- In auxiliary mode, all playback and volume will be adjusted with the controls on your connected device.
- The headphones will automatically power OFF when a 3.5 mm AUX cable is inserted.

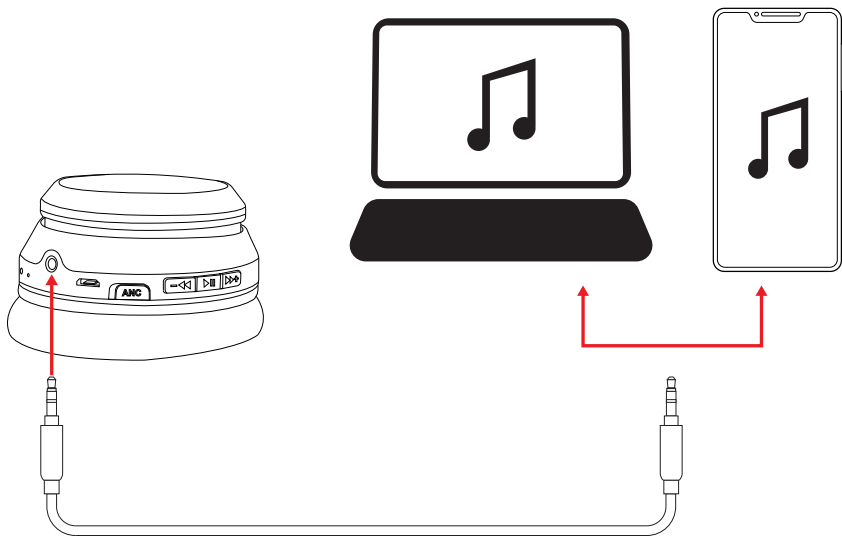

Warranty Information

90-Day Limited Warranty

Territory: United States/Canada

LIMITED WARRANTY TO ORIGINAL CONSUMER

This product as supplied and distributed new by an authorized retailer is warranted by Southern Telecom, Inc. to the original consumer purchaser against defects in materials and workmanship ("Warranty") as follows:

To obtain warranty service:

- Visit our customer support portal: www.customersupport123.com
- Select the brand and model of your device
- Select "Service Request" and fill out the form to begin your inquiry
- Exchanges require dated proof of purchase from an authorized retailer

Your product will be repaired or replaced, at our option, for the same or similar model of equal value if examination by the service center determines this product is defective. Products received damaged as a result of shipping will require you to file a claim with the carrier.

Warranty service not provided

This warranty does not cover damage resulting from accident, misuse, abuse, improper installation or operation, lack of reasonable care, unauthorized modification including software modifications such as the installation of custom firmware. This warranty is voided in the event any unauthorized person opens, alters or repairs this product. All products being returned to the authorized service center for repair must be suitably packaged.

Warranty (cont'd)

NO WARRANTIES, WHETHER EXPRESS OR IMPLIED, INCLUDING, BUT NOT LIMITED TO, ANY IMPLIED WARRANTIES OF MERCHANTABILITY OR FITNESS FOR A PARTICULAR PURPOSE, OTHER THAN THOSE EXPRESSLY DESCRIBED ABOVE SHALL APPLY. DISTRIBUTOR FURTHER DISCLAIMS ALL WARRANTIES AFTER THE EXPRESS WARRANTY PERIOD STATED ABOVE. NO OTHER EXPRESS WARRANTY OR GUARANTY GIVEN BY ANY PERSON, FIRM OR ENTITY WITH RESPECT TO THE PRODUCT SHALL BE BINDING ON DISTRIBUTOR. REPAIR, REPLACEMENT, OR REFUND OF THE ORIGINAL PURCHASE PRICE - AT DISTRIBUTOR'S SOLE DISCRETION - ARE THE EXCLUSIVE REMEDIES OF THE CONSUMER. IN NO EVENT WILL DISTRIBUTOR OR ITS MANUFACTURERS BE LIABLE FOR ANY INCIDENTAL, DIRECT, INDIRECT, SPECIAL, PUNITIVE OR CONSEQUENTIAL DAMAGES (SUCH AS, BUT NOT LIMITED TO, DAMAGES FOR LOSS OF PROFITS, BUSINESS, SAVINGS, DATA OR RECORDS) CAUSED BY THE USE, MISUSE OR INABILITY TO USE THE PRODUCT. EXCEPT AS STATED HEREIN, NO OTHER WARRANTIES SHALL APPLY. NOTWITHSTANDING THE FOREGOING, CONSUMER'S RECOVERY AGAINST DISTRIBUTOR SHALL NOT EXCEED THE PURCHASE PRICE OF THE PRODUCT SOLD BY DISTRIBUTOR. THIS WARRANTY SHALL NOT EXTEND TO ANYONE OTHER THAN THE ORIGINAL CONSUMER WHO PURCHASED THE PRODUCT AND IS NOT TRANSFERABLE.

Some countries, states or provinces do not allow the exclusion or limitation of incidental or consequential damages or allow limitations on warranties, so limitation or exclusions may not apply to you. This warranty gives you specific legal rights, and you may have other rights that vary from state to state or province to province. Contact your authorized retailer to determine if another warranty applies.

Brookstone®

Brookstone© trademark, name and logos are trademarks of BKST Brand Holdings LLC and used under license.

Manufactured and Marked by Southern Telecom, Inc. under license.

Southern Telecom
Brooklyn, NY 11220

Model No.: BSNCH102