

Brookstone®

airphones®

RF WIRELESS HEADPHONE SYSTEM



IN THE BOX



RF Wireless Headphones

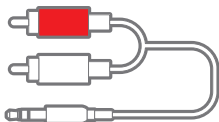

RCA/3.5mm Audio Cable

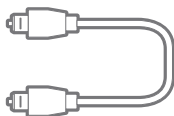

Optical Cable

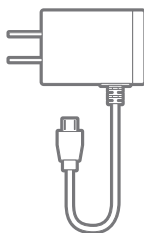

USB Charger

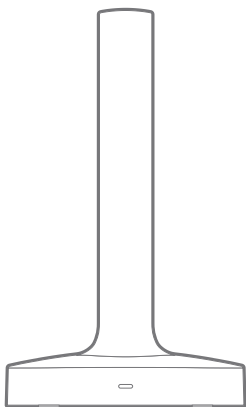

Charging Base



User Guide

LOCATION OF CONTROLS – HEADPHONES

FRONT



SIDE

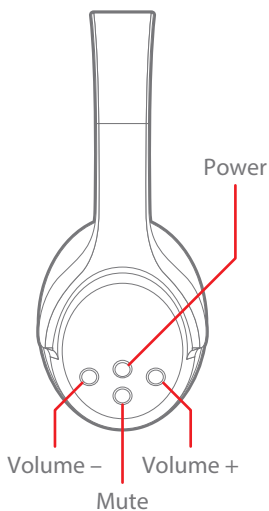

LOCATION OF CONTROLS – CHARGING BASE

TOP

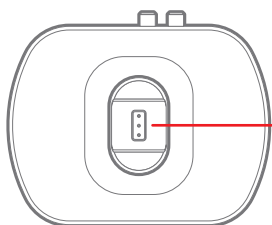

Headphones
Charging
Connector

FRONT

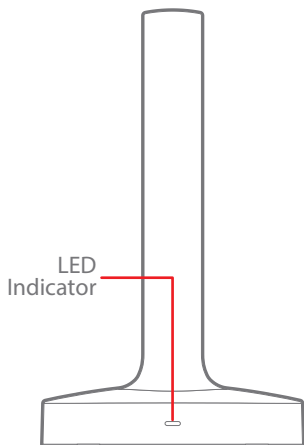

LED
Indicator

BACK

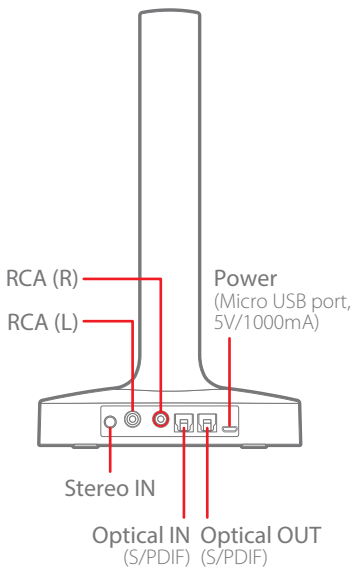

RCA (R)

RCA (L)

Stereo IN

Optical IN (S/PDIF)
Optical OUT (S/PDIF)

Power
(Micro USB port,
5V/1000mA)

BOTTOM

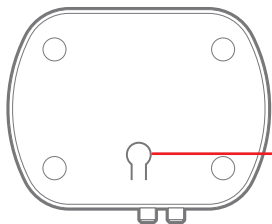

Pairing
Button

CHARGING

1. Connect the supplied USB charger to the Charging Base's USB port.

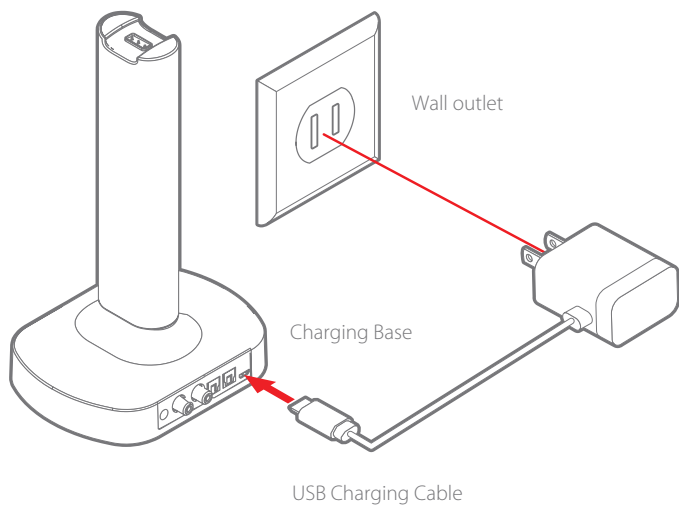

2. Place the headphones on the Charging Base, the headphones and Charging Base LED indicators will light red. Once the headphones are fully charged, both the headphones and the Charging Base's LED indicators will turn off.

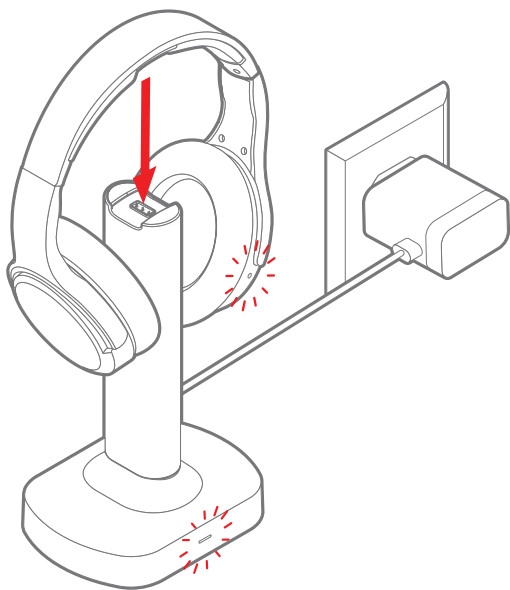

Note:

- Loss of sound quality is an indication that your headphones require charging
- The headphones will automatically power off after 5 minutes of inactivity

CONNECTING THE CHARGING BASE TO A TV

Using the RCA/3.5mm Audio Cable

1. Connect the white and red plugs of the supplied RCA/3.5mm Audio Cable to the (L) and (R) audio out on your television's connection panel.

Note: Ensure the cables are NOT plugged into the TV's audio input.

2. Connect the 3.5mm stereo plug to the Charging Base's Stereo In 3.5mm audio jack as shown below.

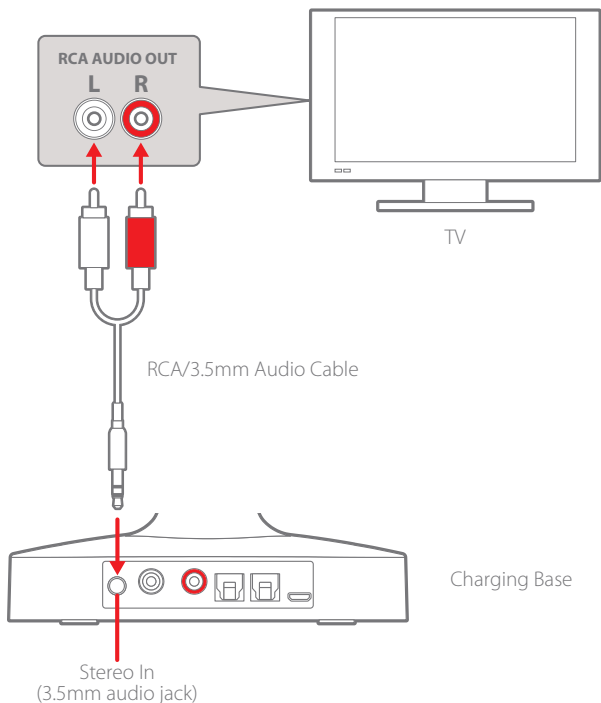

Note: You can also use a 3.5mm/3.5mm audio cable (not included) to connect from a TV's 3.5mm output to the Charging Base's 3.5mm stereo input.

Passthrough

After connecting your TV to the Charging Base's 3.5mm stereo input, you can passthrough the sound to your soundbar or other audio device as shown below.

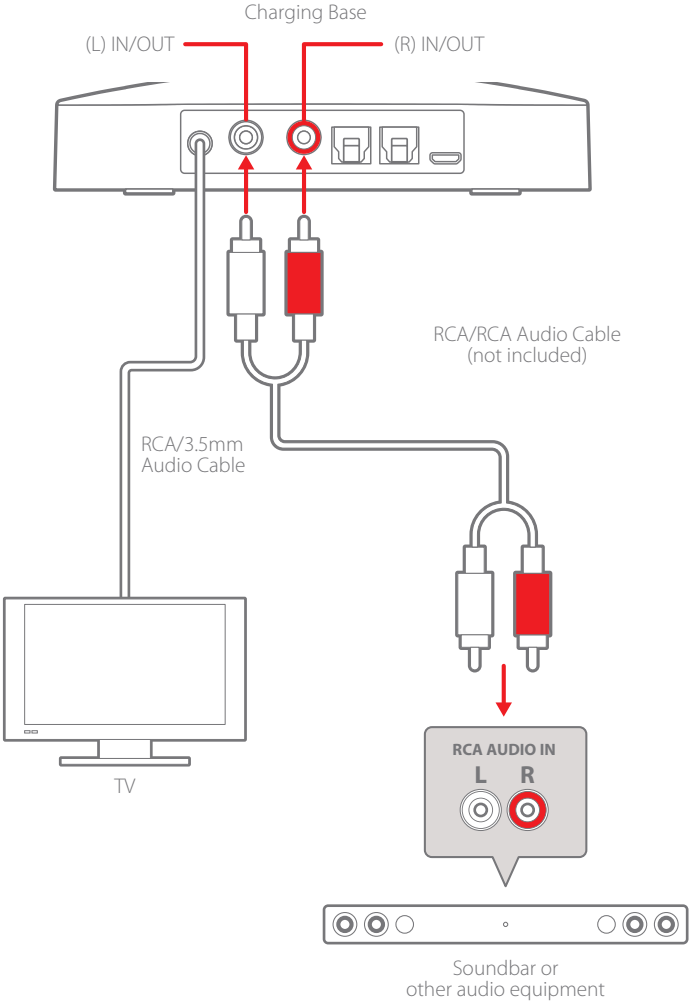

Using the S/PDIF optical cable for digital audio

For televisions equipped with an S/PDIF optical output, you may connect the included Optical Cable to the TV's connection panel. Connect the other end of the Optical Cable into the Charging Base's "Optical IN" port (supports 96kHz/24bit).

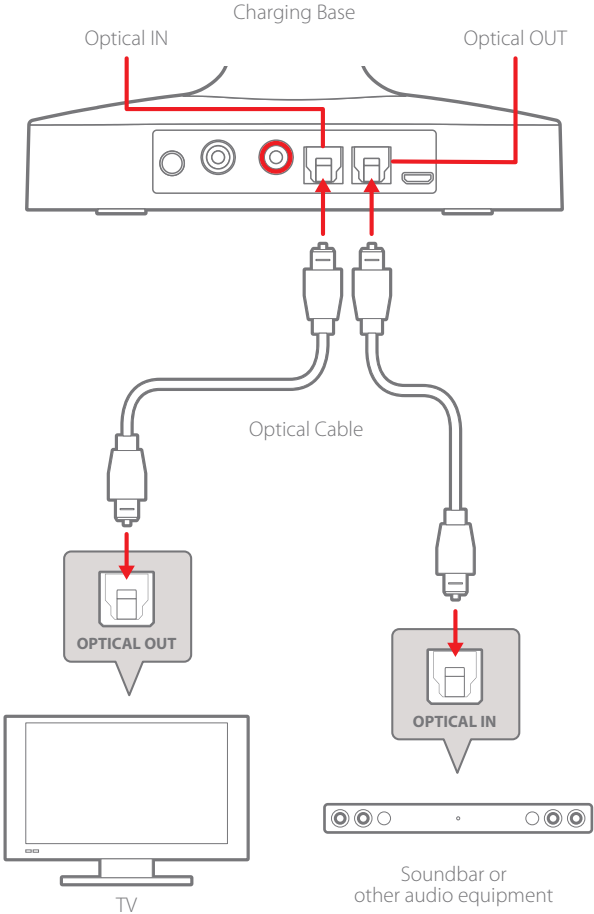

If you have a sound bar or other audio equipment already connected to your television, you can use the Charging Base's audio passthrough connection labeled "Optical OUT" to connect to your other audio equipment.

When an audio source is connected to the Charging Base's "STEREO IN", the optical ports will not function.

Note: If you connect the Charging Base to your TV using the Optical Cable and you notice that there is either no sound or no sound on certain content, please follow the steps below.

1. Make sure your home theater or stereo system is set to the appropriate audio output for the optical connection and that the Optical Cable is securely connected to the TV and Charging Base.
2. Go into the "SOUND", or "SPEAKERS" menu of the TV, and select "EXTERNAL SPEAKERS" or "AUDIO SYSTEM".
Some TVs require that the internal speakers be turned off before outputting the audio signal to another device.
3. Set the "DIGITAL AUDIO OUT" setting on the TV to "PCM".

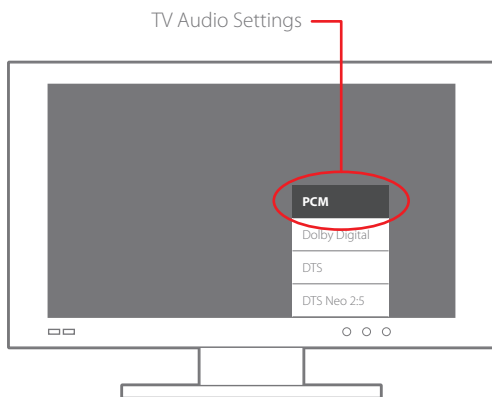

POWER ON/OFF

Power On:

Press and **HOLD** the power button (about 2 seconds), until the headphone's LED Indicator turns blue.

Power Off:

Press and **HOLD** the power button (about 2 seconds), until the headphone's LED Indicator flashes blue and turns off.

Note: If the headphones are powered on and placed on the Charging Base, the headphones will automatically power off.

After powering on the headphones, they will wirelessly connect to the Charging Base (about 5-10 seconds). The Charging Base's LED Indicator will light up solid blue and the headphones will beep three times, its LED Indicator will also flash blue.

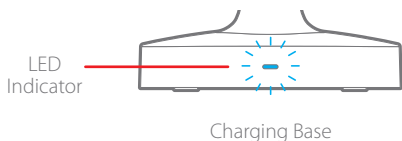
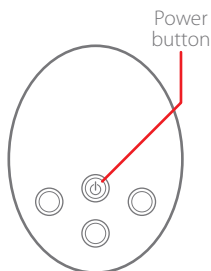

Under ideal conditions, it's possible to achieve a wireless connection of approximately 100 feet*.

Volume

Press the + or – buttons to control the volume.

Press the Mute button to mute the sound and press it again to restore the sound back to the previous level.

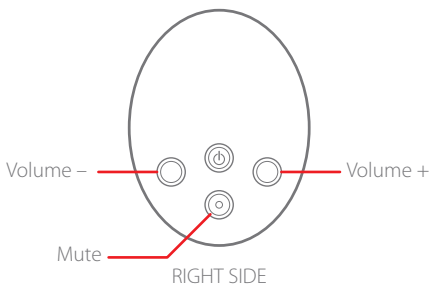

Note: When increasing the volume from the headphones, a max volume tone will be heard when the maximum volume is reached. The max volume tone represents the maximum volume of the headphone's volume controller; however, it may be possible that the device volume is not at the highest position. In that case, it can still be increased from the volume control of the connected device.

Pairing Button:

Whenever you cannot hear sound coming from your connected device, press and **HOLD** the Pairing Button for 3 seconds.

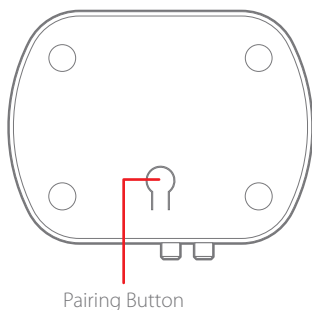

FCC INFORMATION

This device complies with Part 15 of the FCC Rules. Operation is subject to the following two conditions:

- (1) this device may not cause harmful interference, and
- (2) this device must accept any interference received, including interference that may cause undesired operation.

Warning: Changes or modifications to this unit not expressly approved by the party responsible for compliance could void the user's authority to operate the equipment.

NOTE: This equipment has been tested and found to comply with the limits for a Class B digital device, pursuant to Part 15 of the FCC Rules. These limits are designed to provide reasonable protection against harmful interference in a residential installation. This equipment generates, uses and can radiate radio frequency energy and, if not installed and used in accordance with the instructions, may cause harmful interference to radio communications. However, there is no guarantee that interference will not occur in a particular installation. If this equipment does cause harmful interference to radio or television reception, which can be determined by turning the equipment off and on, the user is encouraged to try to correct the interference by one or more of the following measures:

- Reorient or relocate the receiving antenna.
- Increase the separation between the equipment and receiver.
- Connect the equipment into an outlet on a circuit different from that to which the receiver is connected.
- Consult the dealer or an experienced radio/ TV technician for help

Information Regarding Exposure to Radio Frequency Energy

Your device is designed and manufactured not to exceed the emission limits for exposure to RF energy set by the Federal Communications Commission of the United States (FCC). Information on your Device is on file with the FCC and can be found under the Display Grant section of <http://www.fcc.gov/oet/ea/> after searching on the FCC ID for your Device, which can be found on the back of the Device.

LITHIUM POLYMER BATTERY WARNINGS

This device contains a non-removable Lithium-Polymer battery. The battery must be recycled or disposed of properly. Contact your local waste management office for information on battery recycling or disposal.



Rating Label Definitions

 Direct current symbol.



This symbol signifies the product must not be discarded as household waste, and should be delivered to an appropriate collection facility for recycling. Proper disposal and recycling helps protect natural resources, human health and the environment.



This symbol signifies and declares that this equipment has battery charging which complies with California CEC and energy efficiency.

LIMITED WARRANTY

1-Year Limited Warranty

Territory: United States

LIMITED WARRANTY TO ORIGINAL CONSUMER

This product (including any accessories included in the original packaging) as supplied and distributed new by an authorized retailer is warranted by Southern Telecom, Inc. to the original consumer purchaser against defects in materials and workmanship ("Warranty") as follows:

To obtain warranty service:

- Visit our customer support portal: **www.customersupport123.com** and select **"Support"**.
- Select the brand, fill out the corresponding form (exchanges require dated proof of purchase from an authorized retailer) then submit your request.

Your product will be repaired or replaced, at our option, for the same or similar model of equal value if examination by the service center determines this product is defective. Products received damaged as a result of shipping will require you to file a claim with the carrier.

Warranty service not provided

This warranty does not cover damage resulting from accident, misuse, abuse, improper installation or operation, lack of reasonable care, unauthorized modification including software modifications such as the installation of custom firmware. This warranty is voided in the event any unauthorized person opens, alters or repairs this product. All products being returned to the authorized service center for repair must be suitably packaged.

NO WARRANTIES, WHETHER EXPRESS OR IMPLIED, INCLUDING, BUT NOT LIMITED TO, ANY IMPLIED WARRANTIES OF MERCHANTABILITY OR FITNESS FOR A PARTICULAR PURPOSE, OTHER THAN THOSE EXPRESSLY DESCRIBED ABOVE SHALL APPLY. DISTRIBUTOR FURTHER DISCLAIMS ALL WARRANTIES AFTER THE EXPRESS WARRANTY PERIOD STATED ABOVE. NO OTHER EXPRESS WARRANTY OR GUARANTY GIVEN BY ANY PERSON, FIRM OR ENTITY WITH RESPECT TO THE PRODUCT SHALL BE BINDING ON DISTRIBUTOR. REPAIR, REPLACEMENT, OR REFUND OF THE ORIGINAL PURCHASE PRICE - AT DISTRIBUTOR'S SOLE DISCRETION - ARE THE EXCLUSIVE REMEDIES OF THE CONSUMER. IN NO EVENT WILL DISTRIBUTOR OR ITS MANUFACTURERS BE LIABLE FOR ANY INCIDENTAL, DIRECT, INDIRECT, SPECIAL, PUNITIVE OR CONSEQUENTIAL DAMAGES (SUCH AS, BUT NOT LIMITED TO, DAMAGES FOR LOSS OF PROFITS, BUSINESS, SAVINGS, DATA OR RECORDS) CAUSED BY THE USE, MISUSE OR INABILITY TO USE THE

PRODUCT. EXCEPT AS STATED HEREIN, NO OTHER WARRANTIES SHALL APPLY. NOTWITHSTANDING THE FOREGOING, CONSUMER'S RECOVERY AGAINST DISTRIBUTOR SHALL NOT EXCEED THE PURCHASE PRICE OF THE PRODUCT SOLD BY DISTRIBUTOR. THIS WARRANTY SHALL NOT EXTEND TO ANYONE OTHER THAN THE ORIGINAL CONSUMER WHO PURCHASED THE PRODUCT AND IS NOT TRANSFERABLE.

Some countries, states or provinces do not allow the exclusion or limitation of incidental or consequential damages or allow limitations on warranties, so limitation or exclusions may not apply to you. This warranty gives you specific legal rights, and you may have other rights that vary from state to state or province to province. Contact your authorized retailer to determine if another warranty applies.

Made in China v2.0 12-2021

Brookstone[®]