

(Front)

KNIGHT LITE

LED Decora Wall-Outlet Cover

ASOTV-LEDFP-CVR

Instruction Manual

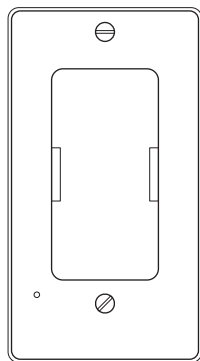

Before You Begin...

Questions & Customer Support

For any questions or support with our product, please visit us at our website at SouthernTelecom.com and click on **Product Support**.

Read and keep these instructions. Heed all warnings.

WARNING

It is **ABSOLUTELY CRITICAL** that power has been shut off from the fuse panel or circuit breaker box to the designated outlet before installing this item. **Placement of this item CANNOT BE DONE SAFELY UNLESS POWER HAS BEEN DISCONNECTED at the breaker panel or fuse panel for the property.**

ONCE POWER HAS BEEN DISCONNECTED, test the outlet using a voltage meter capable of making the proper readings PRIOR to the installation of the item to ensure that the power has been properly disconnected.

If you are unsure or confused about anything presented in this manual involving disconnecting the power to a circuit, **please consult a QUALIFIED ELECTRICIAN.**

In the Box

- Duplex Outlet Cover (x1)
- 6 mm Screw (x2)
- Instruction Manual (x1)

Specifications

ASOTV-LEDFP-CVR
Knight Lite
Input: AC 110V
Power: 0.3W

Installation

1. Turn Off the Power

Locate the electrical cutoff point (fuse box, breaker panel, etc.) and turn off the power to the outlet being used by turning off the breaker switch or removing the fuse, as necessary.

NOTE: If you are unsure what this is or where it is located, please consult a qualified electrician.

After the outlet is powered OFF, test it using a voltage meter or by plugging a device into the outlet, such as a light, and turning it ON.

Once you have confirmed that the power to the outlet is OFF, you may proceed to step 2.

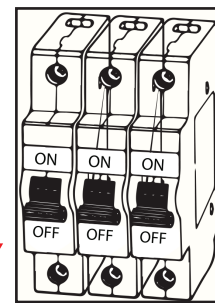

2. Remove the Existing Outlet Cover

NOTE: This section will require the use of a screw driver.

Unscrew and remove the existing cover from the wall to reveal the outlet.

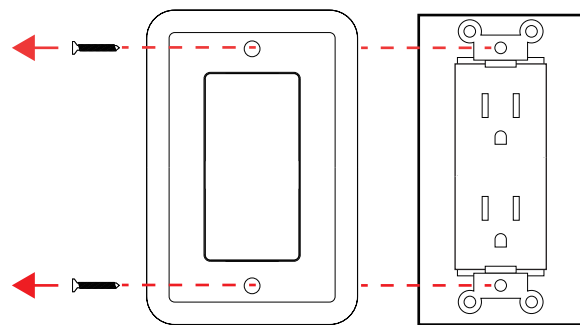

3. Install the Outlet Cover

Slide the outlet cover into the outlet so that **the two prongs clip into place** on both sides of the middle of the outlet.

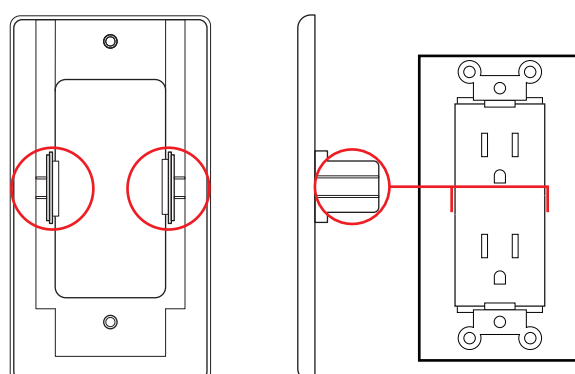

4. Finish Up

Screw both outlet cover screws into the outlet's top and bottom screw holes.

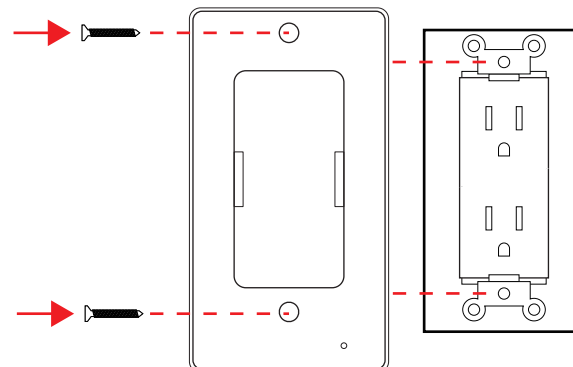

Return power to the outlet via breaker or circuit box and test to ensure it is functioning. The LED lights on the outlet cover will turn on automatically when the room is dark and turn off when the room is light.

(Back)

Compliance Information

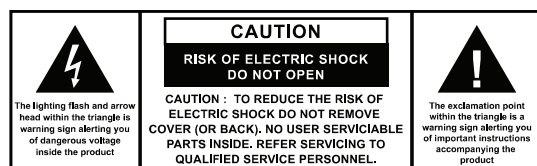

1. Follow all instructions.
2. Do not use this apparatus near water.
3. Clean only with a dry cloth.
4. Do not block any ventilation openings. Install in accordance with the manufacturer's instructions.
5. Do not install near any heat sources such as radiators, heat registers, stoves, or other apparatus (including amplifiers) that produce heat.
6. Do not defeat the safety purpose of the polarized or grounding-type plug. A polarized plug has two blades with one wider than the other. A grounding type plug has two blades and a third grounding prong. The wide blade or the third prong are provided for your safety. When the provided plug does not fit into your outlet, consult an electrician for replacement of the obsolete outlet.
7. Only use attachments/accessories specified by the manufacturer.
8. Refer all servicing to qualified service personnel. Servicing is required when the apparatus has been damaged in any way, such as power-supply cord or plug is damaged; liquid has been spilled or objects have fallen into the apparatus; the apparatus has been exposed to rain or moisture, does not operate normally, or has been dropped.
9. **WARNING:** The mains plug is used as a disconnect device; the disconnect device shall remain readily operable.
10. **WARNING:** To reduce the risk of fire or electric shock, do not expose this apparatus to rain or moisture. The apparatus shall not be exposed to dripping or splashing, and objects filled with liquids, such as vases, shall not be placed on apparatus.

READ CAREFULLY AND KEEP THIS MANUAL

FCC Information

This device complies with Part 15 of the FCC Rules.

Caution: Any changes or modifications not expressly approved could void the user's authority to operate the equipment.

Note: This equipment has been tested and found to comply with the limits for a Class B digital device, pursuant to part 15 of the FCC Rules. These limits are designed to provide reasonable protection against harmful interference in a residential installation. This equipment generates, uses and can radiate radio frequency energy and, if not installed and used in accordance with the instructions, may cause harmful interference to radio communications. However, there is no guarantee that interference will not occur in a particular installation. If this equipment does cause harmful interference to radio or television reception, which can be determined by turning the equipment off and on, the user is encouraged to try to correct the interference by one or more of the following measures:

- Reorient or relocate the receiving antenna.
- Increase the separation between the equipment and receiver.
- Connect the equipment into an outlet on a circuit different from that to which the receiver is connected.
- Consult the dealer or an experienced radio/TV technician for help.

Rain/Moisture Warning

- Do not expose the unit to extreme temperatures (heat or cold), open flames, humid conditions, or wet conditions.
- Do not submerge in water.
- Do not open this product or attempt to repair the unit yourself should it not be working.

Warranty Information

This product as supplied and distributed new by Southern Telecom, Inc. to the original consumer purchaser is warranted by Southern Telecom against defects in material and workmanship for a period of one year from your date of purchase ("Warranty"). In the unlikely event that this product is defective, or does not perform properly, you may within one year from your original date of purchase return it to the authorized service center for repair or exchange.

Obtaining Warranty Service

To obtain warranty service on your product go to our website, SouthernTelecom.com, and click on **Product Support**. Select **Knight Lite**, then click on **Service Request** to get started.

Your product will be repaired or replaced, at our option, for the same or similar model of equal value if examination by the service center determines this product is defective. Products received damaged as a result of shipping, will require you to file a claim with the carrier.

Warranty Service Not Provided

This warranty does not cover damage resulting from accident, misuse, abuse, improper installation or operation, lack of reasonable care, and unauthorized modification. This warranty is voided in the event any unauthorized person opens, alters or repairs this product. All products being returned to the authorized service center for repair must be suitably packaged.

Limitation of Warranty

The warranty stated above is the only warranty applicable to this product. All other warranties, express or implied (including all implied warranties of merchantability or fitness for a particular purpose) are hereby disclaimed. No verbal or written information given by Southern Telecom, Inc. its agents, or employees shall create a warranty or in any way increase the scope of this warranty. Repair or replacement as provided under this warranty is the exclusive remedy of the consumer. Southern Telecom, Inc. shall not be liable for incidental or consequential damages resulting from the use of this product or arising out of any breach of any express or implied warranty on this product. This disclaimer of warranties and limited warranty are governed by the laws of the State of New York. Except to the extent prohibited by applicable law, any implied warranty of merchantability or fitness for a particular purpose on this product is limited to the applicable warranty period set forth above.

Some countries, states or provinces do not allow the exclusion or limitation of incidental or consequential damages or allow limitations on warranties, so limitation or exclusions may not apply to you. This warranty gives you specific legal rights, and you may have other rights that vary from state to state or province to province. Contact your authorized retailer to determine if another warranty applies.

All product names, trademarks, and registered trademarks are property of their respective owners. All company, product, and service names used in this document are for identification purposes only. Use of these names, trademarks, and brands does not imply endorsement.

Printed in China
Designed in USA
v1. 12-2018